

## Fuel Pump Locking Tool Kit Fits-For VW Audi Porsche VAG TDi 2.7/3.0



### Introduction:

Fuel pump drive belt kit VAG 2.9/3Lt TDi for locking the fuel pump into its timed position so that the pump drive belt can be replaced or the pump timing checked.

Item	Description	OEM No.
<b>A</b>	High Pressure Pump Locking Tool	T40135
<b>B</b>	Crankshaft Locking	T40237
<b>C</b>	Camshaft Sprocket Puller	T10320
<b>D</b>	Crankshaft Turning Tool	T40058

Manufacturer	Model	Year	Type
<b>Audi</b>	Q5	2008-2012	TDI CR TDI TDI CR clean diesel TDI CR BlueMotion
	A5 Coupe	2007-2012	
	A4	2007-2012	
	Q7	2007-2012	
	A6 Quattro	2008-2011	
<b>Porsche</b>	Cayenne	2008-2016	
<b>Volkswagen</b>	Phaeton	2007-2015	
Engine Code			
<b>2.7</b>	CAMA, CAMB, CANA, CGKA, CGKB, CANC, CAND, CANB		
<b>3</b>	CCWA, CASA, CASB, CDYC, CDYA, CCWB, CCMA, CCLA, CDYB, M05/9D (CAS), M05/9E, CAS, CARA, CEXA, CATA, CASC, CASD, CEXB		

**Instruction:**

※NOTE:Place the trough under the leaking oil.

Follow the rules for sorting garbage!

The toothed belt must not come into contact with oil or coolant!

Installation work on the toothed belt should be carried out only with a cold engine.

When fumbling with a finger, the holes in the meter. Do not turn the crankshaft.

Turn the crankshaft only clockwise.

**Dismantling:**

1. Remove the engine compartment cover (s).
2. Remove the support.
3. Remove the air hose.
4. Remove toothed belt cover.
5. Loosen the tension roller screw (s) two turns. (1)
6. Position the (B) counter. (3)
7. Loosen the bolt (s) of the high-pressure pump drive gear by approximately two turns. (2)

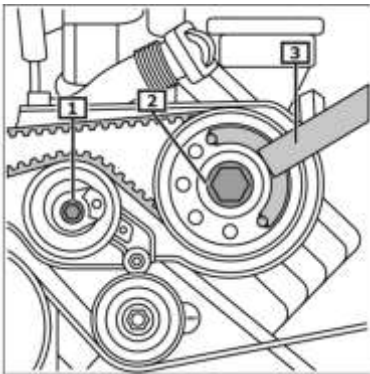

8. Install the puller in the center of the (C) high-pressure pump drive gear. (1)(2).
9. Separate the high-pressure pump drive gear from the shaft with a puller.
10. Remove the timing belt. (3)

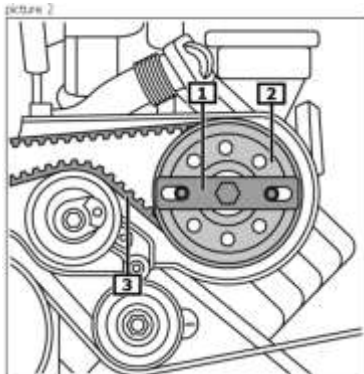
**Installation:**

1. Use (D) an adapter. (1)
2. Arrange the elevation of the meter. crankshaft gears vertically upwards. (1)

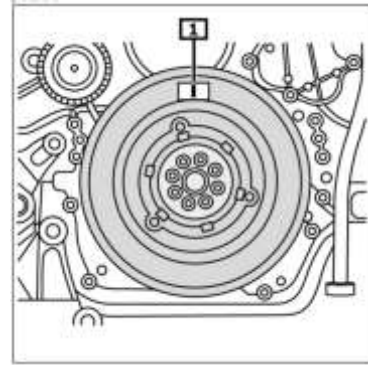

3. Unscrew the rear threaded plug on the right cylinder head. (1)
4. The camshaft slot must match the hole. (2) (3)

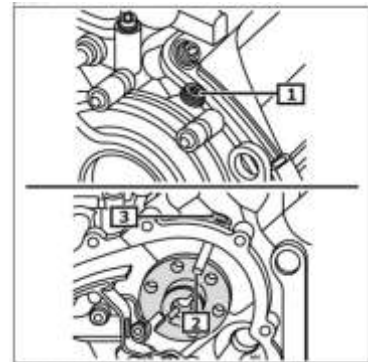

5. Unscrew the screw plug of the upper part of the oil pan. (1)
6. Place the trough under the leaking oil.
- ※Danger of injury!
7. The crankshaft has a groove for the screw plug. (1)
8. Tighten and tighten the (C) crankshaft fixing tool.

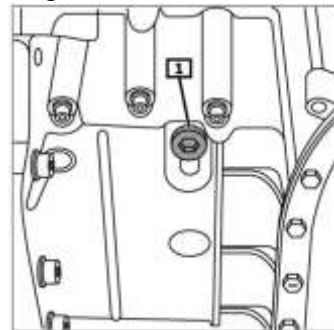

9. The hole in the high-pressure pump gear must be in position for 3 hours (s).
10. (1) (3) Insert the locking pin (s) of the (A) high-pressure pump gear.(2)

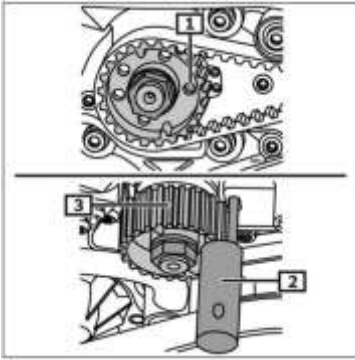

11. Take into account the position of the installation!  
 12. Observe the correct position of the retaining projection (s) of the tensioning roller in the guide.  
 13. (1) The hexagon socket of the tension roller must be in position for 6 hours (s). (2)

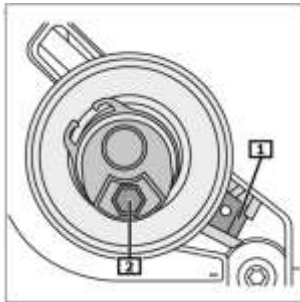

14. Apply toothed belt. (1)  
 15. Screw in the tensioning roller screw (s).  
 16. (2) The camshaft eccentric must still rotate without tipping over.  
 17. Screw in the bolt (s) of the high-pressure pump drive gear. (3)  
 18. The drive gear of the high-pressure pump must be turned by hand and must not wobble.  
 19. Insert the (A) high pressure pump pinion pin.

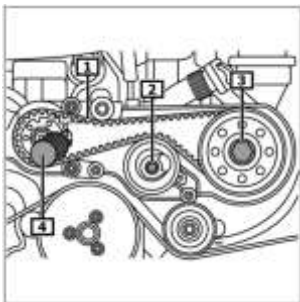

20. Install the camshaft eccentric by turning the anti-clockwise key in the position for one hour. (1)

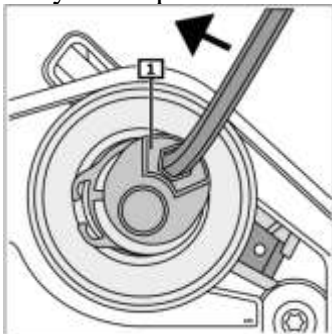

21. Install the camshaft eccentric by turning the locking wrench clockwise to the position for three hours. (1)

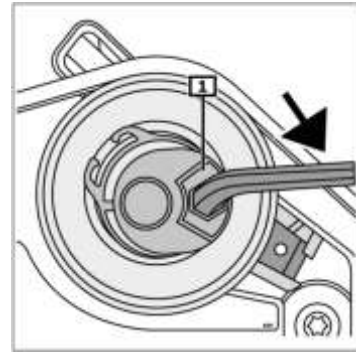

22. Tighten the timing belt so that the notch and protrusion are facing each other. (1) (2)  
 23. Hold the tensioning roller in position. (3)  
 24. Tighten the tensioning roller bolt. (2)

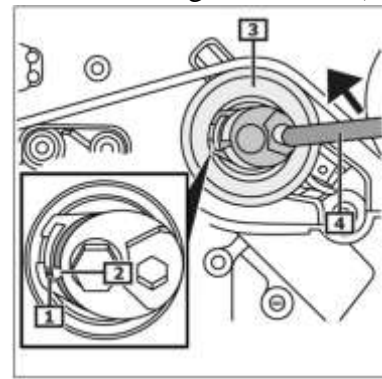

25. To position the (B) counterpart. (3)  
 26. Tighten the bolt of the high-pressure pump drive gear. (2)  
 27. Remove the (B) crankshaft fixing tool.  
 28. Tighten the screw plug of the upper part of the oil pan. (1)  
 29. Turn the crankshaft one turn clockwise.  
 30. Use the (D) adapter. (1)  
 31. Check the tension of the timing belt, correct if necessary.  
 32. The protrusion should be against the notch. (1) (2)  
 33. Further assembly must take place in reverse order of disassembly.

