

US-825 Elevador electrohidráulico de tijera móvil Electrohydraulic scissor hoists (floored model)

CE Made in Italy

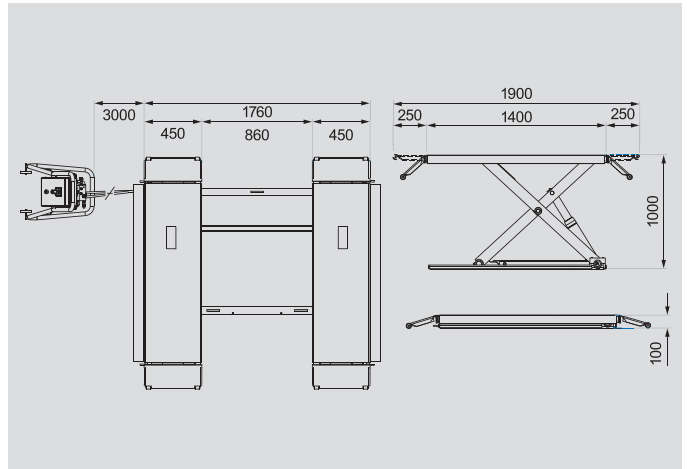
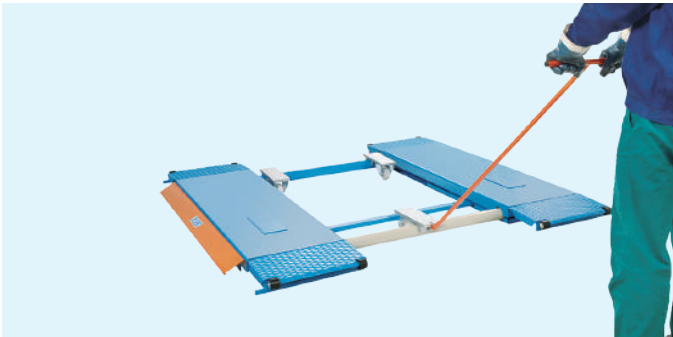

Capacidad Capacity	Potencia Power	Motor trifásico Three-phase motor	Peso Weight
3000 Kg	3,3 Kw	400 V - 50 Hz	610 Kg

Trazado técnico constructivo

- Especialmente adecuado para tiendas de neumáticos, carroceros y mecánicos.
- Doble barra de torsión para nivelación, conexión y linealidad de las dos plataformas.
- Tamaño reducido.
- Dispositivos mecánicos de seguridad de aparcamiento.
- Válvulas de retención y seguridad en caso de rotura de tuberías.
- Funcionamiento electrohidráulico rápido.
- Controles de baja tensión (24 V).
- Rampas de acceso convertibles en extensión plataforma.
- Bujes autolubricantes.
- Aceite para circuito hidráulico suministrado.
- Anclajes de tierra suministrados.

Technical and structural lay-out

- Particularly suitable for tyre-shops, car-body-shops and garages.
- Double torsion bar for levelling, connecting and aligning the two boards.
- Minimal overall dimensions.
- Mechanical standing safeties.
- Check and safety valves against breakage of pipes.
- Electrohydraulic rapid working.
- 24 V low-tension control.
- Drive ramps convertible into standing extension set.
- Self-lubricating bushes.
- Delivered with oil for the hydraulic circuit.
- Equipped with anchor small blocks.