

JAR-156

Prensa hidráulica para bidones "Aplasta latas"
Hydraulic press for drums "Crusher cans"



Prensa para bidones con bomba electrohidráulica. La bomba esta dotada de racor rápido y montada sobre un armario móvil. Estudiada para realizar una veloz y práctica prensada del bidón de chapa, de 1 a 30 litros.

Can press with electro-hydraulic pump. The pump is equipped with a quick really and mounted over a movable cupboard. Studied for faster and practical oil drum pressed, from 1 to 30 litres.

• Peso - Weight: 274 Kg

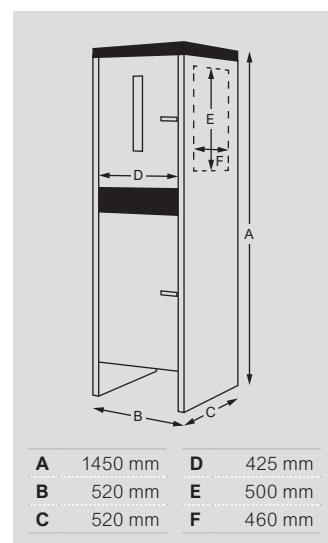

JAR-157

Prensa para bobinas de cartón y papel
Paper and carboard coil press



Prensa de funcionamiento neumático, especial para bobinas de cartón y papel, dotada de doble bloqueo de seguridad y de plataforma inferior parcialmente extraíble para una fácil evacuación de la bobina formada.

Pneumatic working press, special for cardboard coils and paper, equipped with twin safety locking and lower platform partially removable for an easier evacuation of the formed bale.

Capacidad	Capacity	700 Kg
Recorrido pistón	Piston stroke	500 mm
Presión alimentación	Fiding pressure	10 Bar
Peso	Weight	150 Kg

